

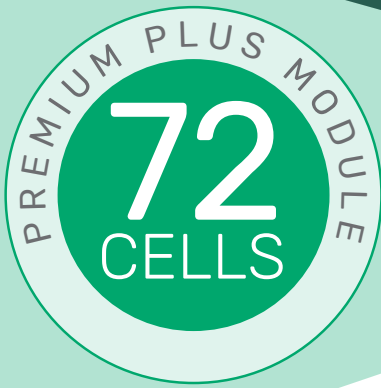

Premium Plus Module

350-360W



More Power

Higher conversion efficiency, more power production per unit area



Lower System Cost

Higher conversion efficiency help to save transportation cost, installation cost and BOS cost



Better Low-light performance

Enhanced spectral response at longer wave length boosts low-light performance, which can produce more than 3% additional power compared with conventional module at system side



Anti-PID



5400Pa

Certified to withstand increased loads of up to 5400pa



1500V - Maximum System Voltage



Fire test resistance



IP68 connectors enhance the reliability of the PV system



10 year product warranty²
25 year performance warranty¹

Note: This datasheet is not legally binding. Phono Solar reserves the right to make specifications changes without notice. Further information can be found on our website: www.phonosolar.com

1. In compliance with our warranty terms and conditions.
2. 12 year product warranty applies when product is registered at phonosolar.com/care

Phono Solar is proudly manufactured in China

PHONO SOLAR AUSTRALIA

Suite 3, 130-134 Pacific Highway, Greenwich NSW 2065

PHONO SALES

184 Bluestone Circuit, Seventeen Mile Rocks QLD 4073

TEL: 07 3160 5259 CONTACT: www.phonosolar.com

Premium Plus Module

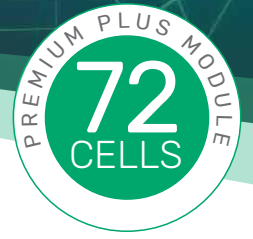

ELECTRICAL TYPICAL VALUES

Model	PS350M-24/T PS350MH-24/T	PS355M-24/T PS355MH-24/T	PS360M-24/T PS360MH-24/T
Type	Monocrystalline 6 inch x 6 inch square, 6 x 12 pieces in series		
Rated Power (Pmpp)	350	355	360
Tolerance	0~+5w	0~+5w	0~+5w
Rated Current (Impp)	9.15	9.22	9.32
Rated Voltage (Vmpp)	38.26	38.51	38.63
Short Circuit Current (Isc)	9.71	9.74	9.82
Open Circuit Voltage (Voc)	47.64	47.76	47.88
Module Efficiency (%)	18.04	18.30	18.55
NOCT (Nominal Operation Cell Temperature)	45°C ± 2°C		
Voltage Temperature Coefficient	-0.288%/°C		
Current Temperature Coefficient	+0.047%/°C		
Power Temperature Coefficient	-0.398%/°C		

MECHANICAL CHARACTERISTICS

Dimension (A x B x C)	Length: 1956mm, Width: 992mm Height: 40mm
Weight	22.5Kg
Front Glass	3.2mm toughened glass
Frame	Anodized aluminium alloy
Cable	4mm ² (IEC)/12AWG (UL), 1100mm
Junction Box	IP 68 rated
Connectors	EVO-2

ABSOLUTE MAXIMUM RATING

Parameter	Values
Operating Temperature	From -40 to +85°C
Hail Diameter @ 80km/h	Up to 25mm
Surface Maximum Load Capacity	Up to 5400Pa
Maximum Series Fuse Rating	20A
IEC Application Class (IEC61730)	A
Fire Rating (IEC61730)	C
Module Fire Performance (UL1703)	Type 1
Maximum System Voltage	DC 1000V (IEC) DC 600V (UL)/1000 (ETL) 1500V (ETL)

PACKING CONFIGURATION

Container	40' HQ	20' GP
Pieces per container	672	230

WEAK LIGHT PERFORMANCE

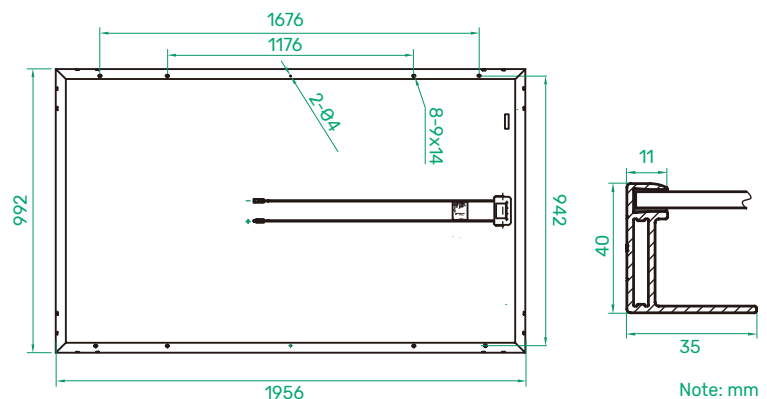
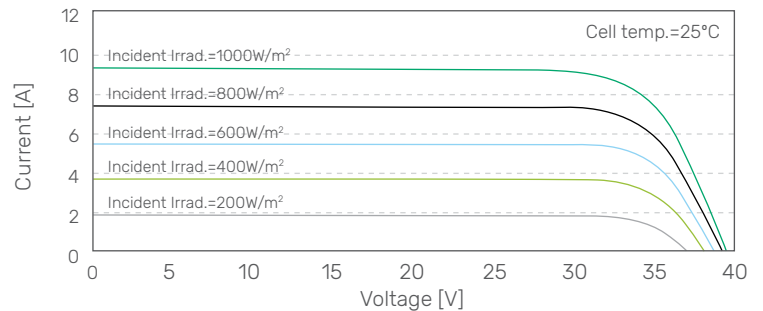
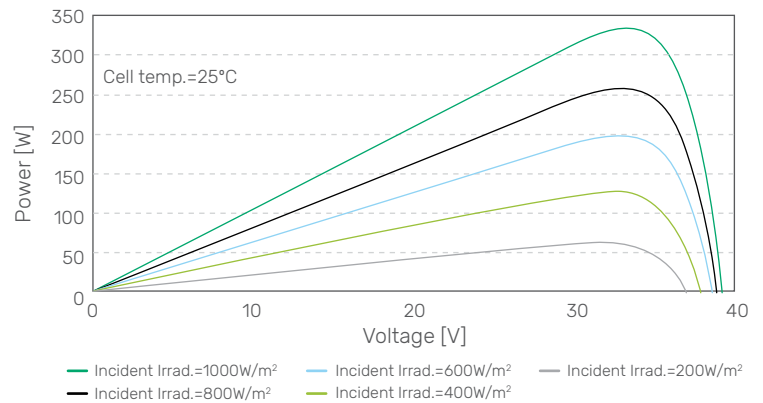

- In compliance with our warranty terms and conditions.
- Measurement conditions under irradiance level of Standard Test Conditions (STC): 1000W/m², Air mass 1.5 Spectrum, cell temperature of 25°C.